

Lecture 8

Step Response & System Behaviour

Prof Peter YK Cheung

Dyson School of Design Engineering

URL: www.ee.ic.ac.uk/pcheung/teaching/DE2_EE/
E-mail: p.cheung@imperial.ac.uk

Lab 3 – Bulb Board

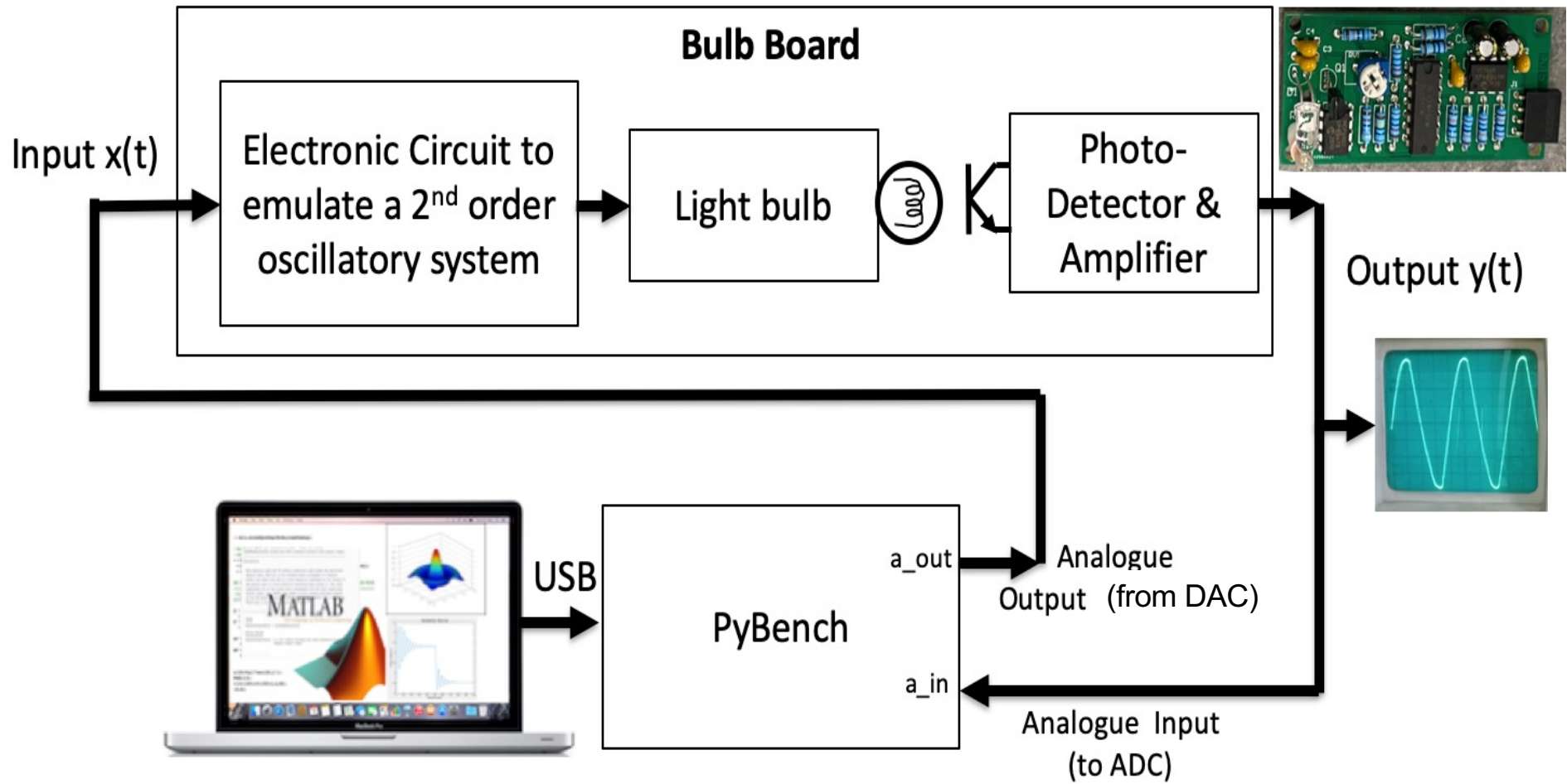

Bulb Board Circuit Schematic

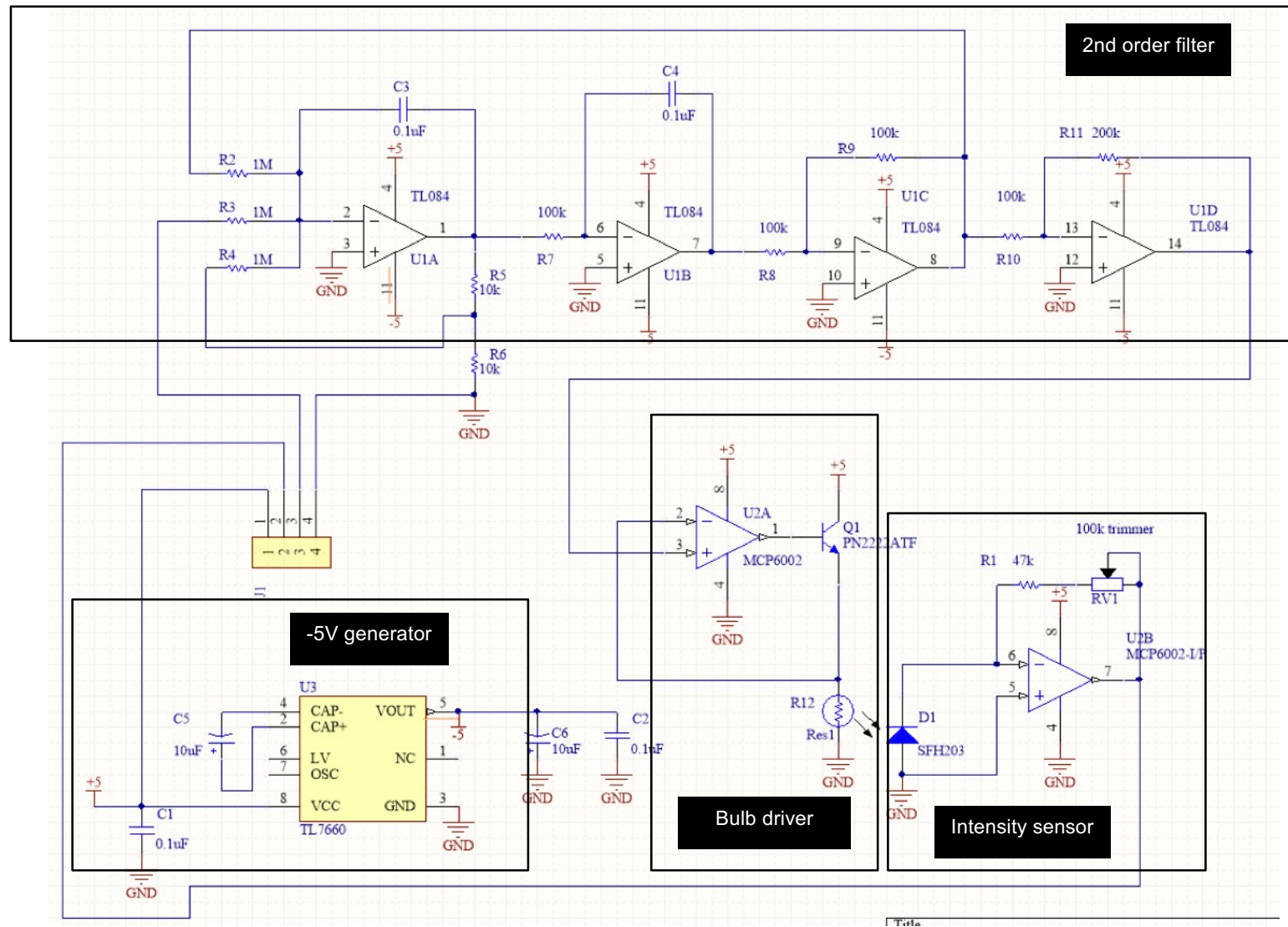

Transfer function of an RC circuit

- ◆ RC low pass filter circuit in Year 1:

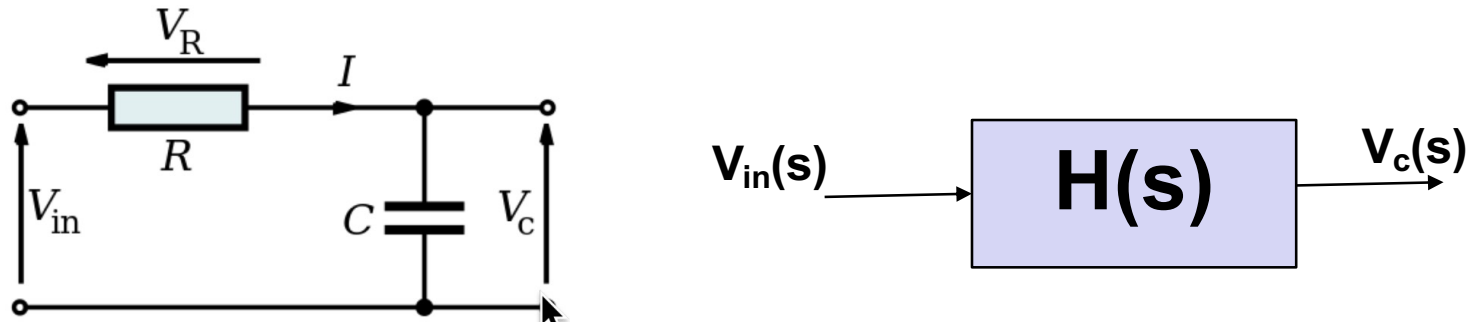

- ◆ Transfer function:

$$H(s) = \frac{V_c(s)}{V_{in}(s)} = \frac{1}{1+\tau s} \quad \tau = RC$$

- ◆ Remember, for a 1st order system, the output step response reaches the following percentages of final value after $n \times \tau$, $n=1,2,3,\dots$:

Time =	τ	2τ	3τ	4τ
Final value	63.2%	86.5%	95%	98.2%

Transfer function of a light bulb

- ◆ In Lab 3, we use the Bulb Board system, and it was known that the light bulb part of the system has a transfer function as shown:



- ◆ Therefore the light bulb itself has an exponential response with a time constant $\tau = 38$ ms.

From Transfer function to Frequency Response

- ◆ Once you know the transfer function $B(s)$ of a system, you can evaluate its frequency response by evaluating $H(s)$ at $s = j\omega$:

$$B(j\omega) = B(s) \Big|_{s=j\omega}$$

- ◆ Therefore, for our light bulb (not including the 2nd order electronic circuit, the frequency response is:

$$B(j\omega) = \frac{1}{(1 + 0.038s)} \Big|_{s=j\omega}$$

$$|B(j\omega)| = \frac{1}{|(1+0.038j\omega)|} = \frac{1}{\sqrt{1+0.038^2\omega^2}}$$

- ◆ From DE1 Electronics 1, you know that this is a low pass filter – gain drops with increasing frequency.

Transfer Function of a 2nd order system

- ◆ Let us consider a general second order system with a transfer function of the general form:

$$H(s) = \frac{Y(s)}{X(s)} = \frac{b_2s^2 + b_1s + b_0}{s^2 + a_1s + a_0}$$

- ◆ To simplify the problem a bit, let us assume that $b_2 = b_1 = 0$. The above equation can be rewritten as:

$$H(s) = \frac{b_0}{s^2 + a_1s + a_0} = K \frac{\omega_0^2}{s^2 + 2\zeta \omega_0s + \omega_0^2}$$

- ◆ where:

- $\omega_0 = \sqrt{a_0}$, the resonant (or natural) frequency in rad/sec
- $\zeta = \frac{a_1}{2\sqrt{a_0}}$, the damping factor (no unit) (pronounced as zeta)
- $K = \frac{b_0}{a_0}$, gain of the system

Physical meaning of ω_0 , ζ , and K

- ◆ Let us take the transfer function $H(s)$ of the 2nd order system used in Bulb Box as an example:



- $\omega_0 = \sqrt{a_0} = 31.62$,

the resonant frequency = 5Hz

- $\zeta = \frac{a_1}{2\sqrt{a_0}} = \frac{5}{2\sqrt{1000}} = 0.079$

the damping factor (very small, ideal = 1)

- $K = \frac{b_0}{a_0} = 1$,

gain of the system at DC or zero frequency

- ◆ Since the damping factor is very small (much smaller than 1), this system is highly oscillatory.

$$H(s) = \frac{b_0}{s^2 + a_1s + a_0} = K \frac{\omega_0^2}{s^2 + 2\zeta\omega_0s + \omega_0^2}$$

The importance of damping factor

- ◆ Let us consider the transfer function $H(s)$ again:

$$H(s) = \frac{b_0}{s^2 + a_1s + a_0} = K \frac{\omega_0^2}{s^2 + 2\zeta\omega_0s + \omega_0^2}$$

- ◆ The unit step response of the system is (i.e. $x(t) = u(t)$, and $X(s) = 1/s$):

$$Y(s) = \frac{1}{s} H(s) = \frac{1}{s} K \frac{\omega_0^2}{s^2 + 2\zeta\omega_0s + \omega_0^2}$$

- ◆ We want to say something about the dynamic characteristic of this system by finding the natural frequency ω_0 and the damping factor ζ .
- ◆ To do that, we find need to find the root of the quadratic: $s^2 + 2\zeta\omega_0s + \omega_0^2$

$$\begin{aligned} s &= \frac{-2\zeta\omega_0 \pm \sqrt{(2\zeta\omega_0)^2 - 4\omega_0^2}}{2} \\ &= -\zeta\omega_0 \pm \omega_0\sqrt{\zeta^2 - 1} \end{aligned}$$

Five cases of behaviour

- Depending on the value of the damping factor ζ , there are five cases of interest, each having a specific behaviour:

$$H(s) = \frac{b_0}{s^2 + a_1s + a_0} = K \frac{\omega_0^2}{s^2 + 2\zeta\omega_0s + \omega_0^2}$$

- Root of denominator:

$$s = -\zeta\omega_0 \pm \omega_0\sqrt{\zeta^2 - 1}$$

Name	Value of ζ	Roots of s	Characteristics of "s"
Overdamped	$\zeta > 1$	$s = -\zeta\omega_0 \pm \omega_0\sqrt{\zeta^2 - 1}$	Two real and negative roots
Critically Damped	$\zeta = 1$	$s = -\omega_0$	A single negative roots
Underdamped	$0 < \zeta < 1$	$s = -\zeta\omega_0 \pm j\omega_0\sqrt{1 - \zeta^2}$	Complex conjugate ($j = \sqrt{-1}$);
Undamped	$\zeta = 0$	$s = \pm j\omega_0$	Pure imaginary (no real part)
Exponential Growth	$\zeta < 0$	$s = -\zeta\omega_0 \pm \omega_0\sqrt{\zeta^2 - 1}$	Roots may be complex or real, but the real part of s is always positive

Step Response for different damping factors

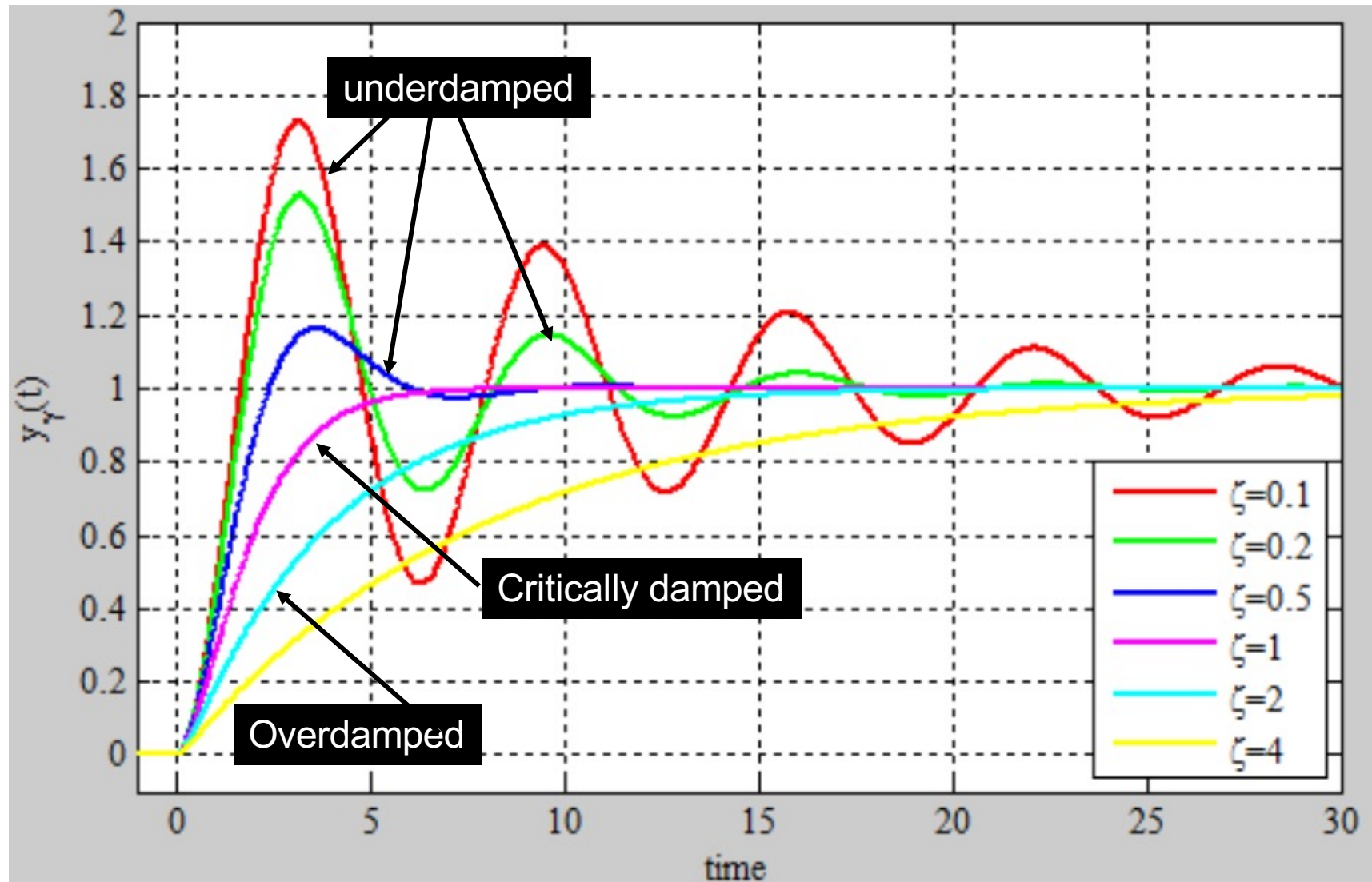

Step Response at $\omega_0, \zeta = 0.2$

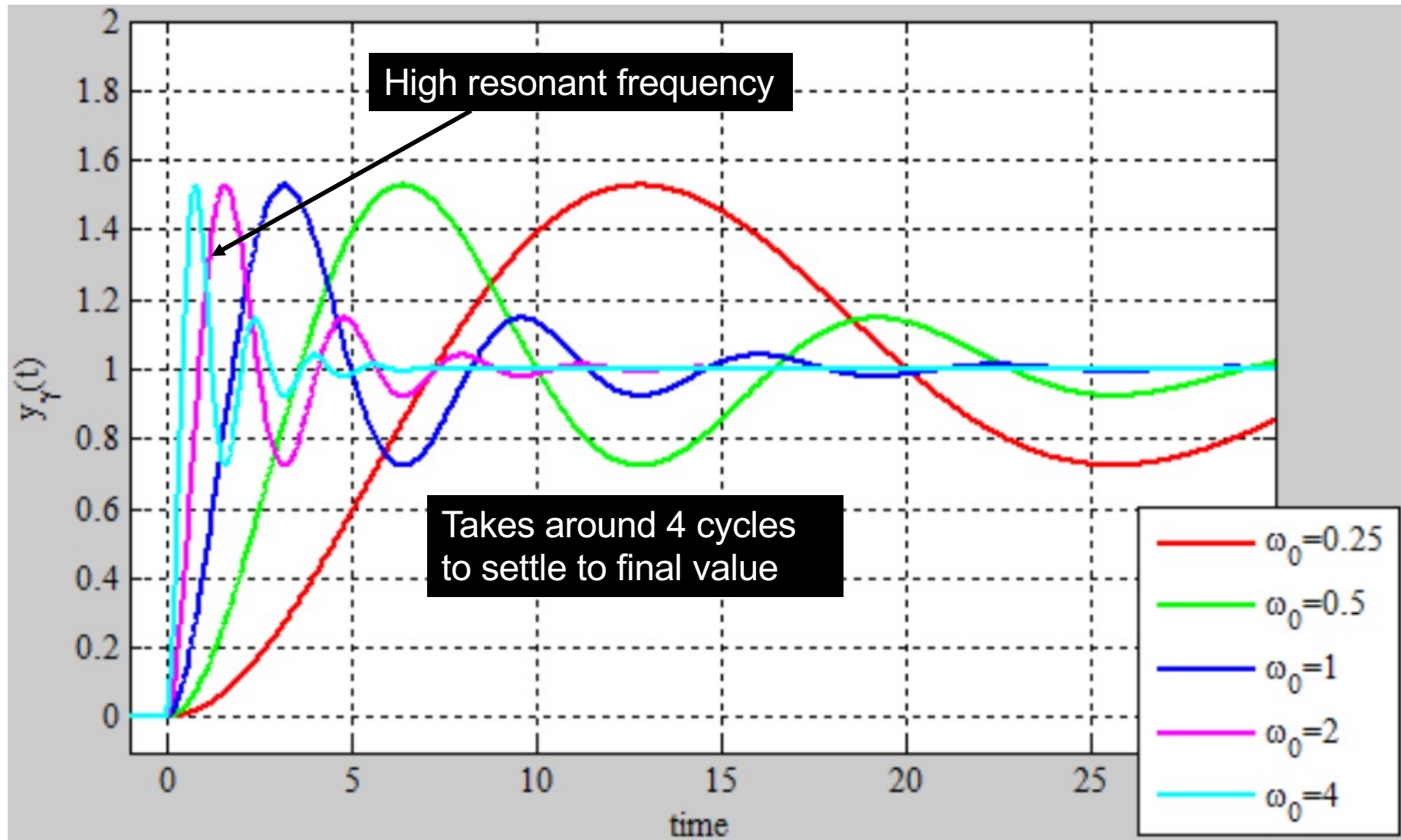

Frequency response of 2nd order system

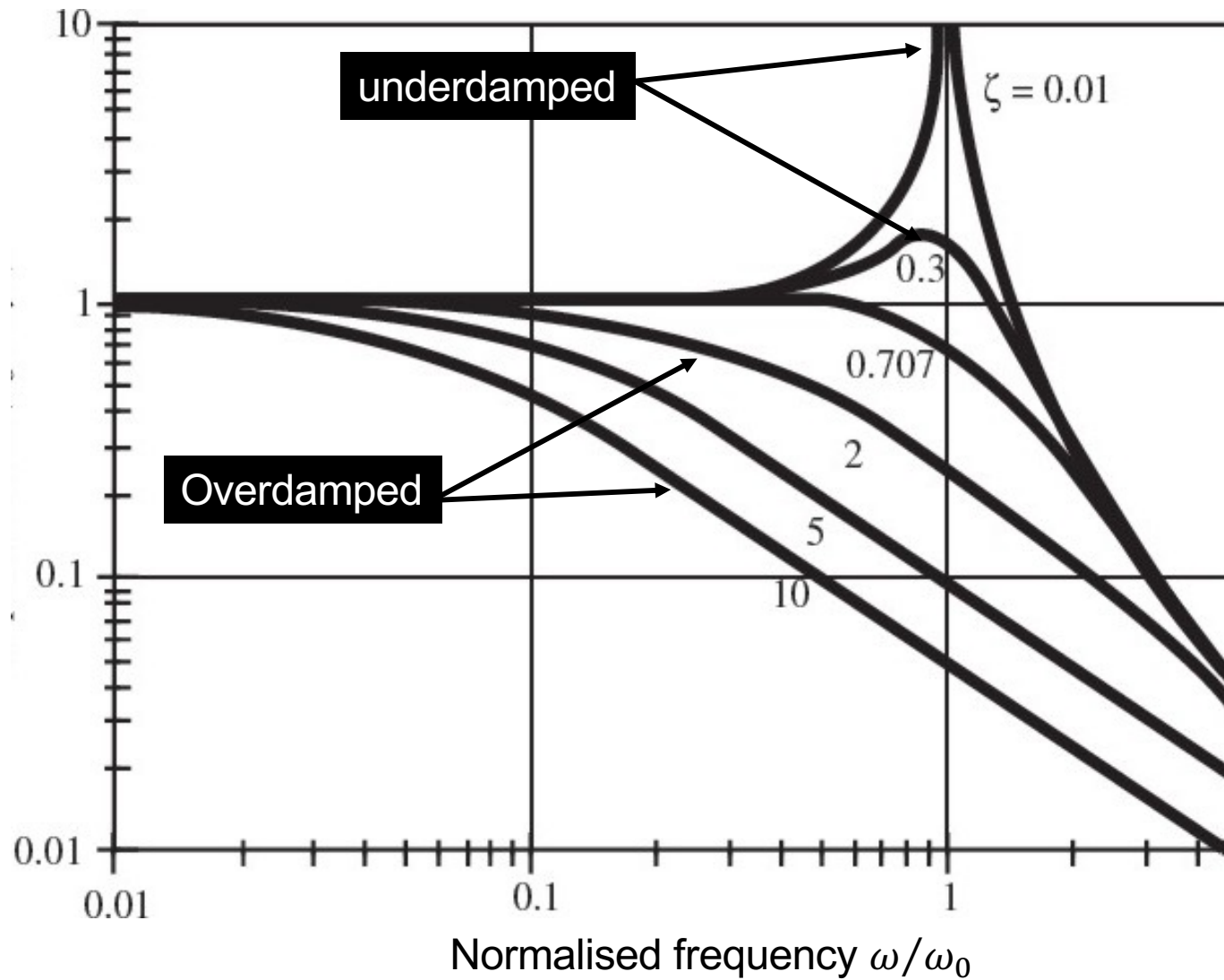

Step Response of a 1st order system

- ◆ Consider what happens to the circuit shown here as the switch is closed at $t = 0$. We are interested in $y(t)$.
- ◆ Apply KVL around the loop, we get:

$$i(t)R + y(t) = x(t), \text{ but } i = C \frac{dy}{dt} \text{ therefore}$$

$$RC \frac{dy}{dt} + y = x$$

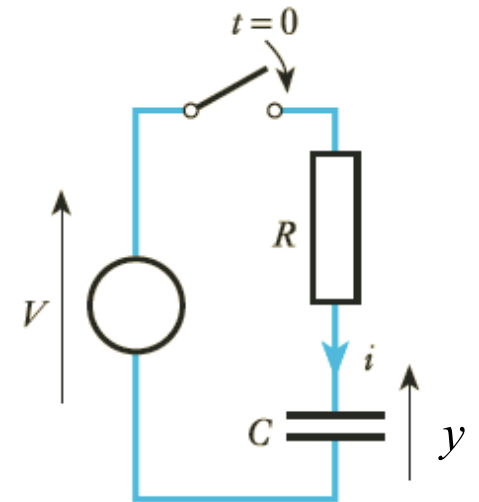

- ◆ This is a simple **first-order differential equation** with constant coefficients.
- ◆ We can model closing the switch at $t=0$ as:

$$x(t) = V u(t)$$

- ◆ Then the solution of the differential equation is:

$$y(t) = V \left(1 - e^{-\frac{t}{RC}} \right) u(t)$$

- ◆ You should be familiar with this from Electronics 1 last year: $\tau = RC$, the time-constant

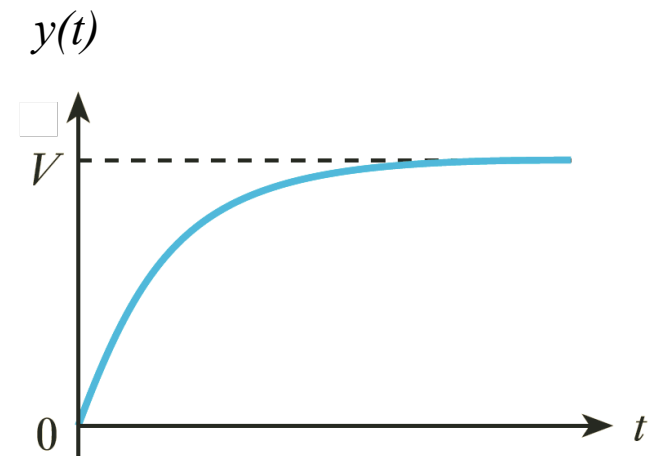

Modelling using Laplace Transform

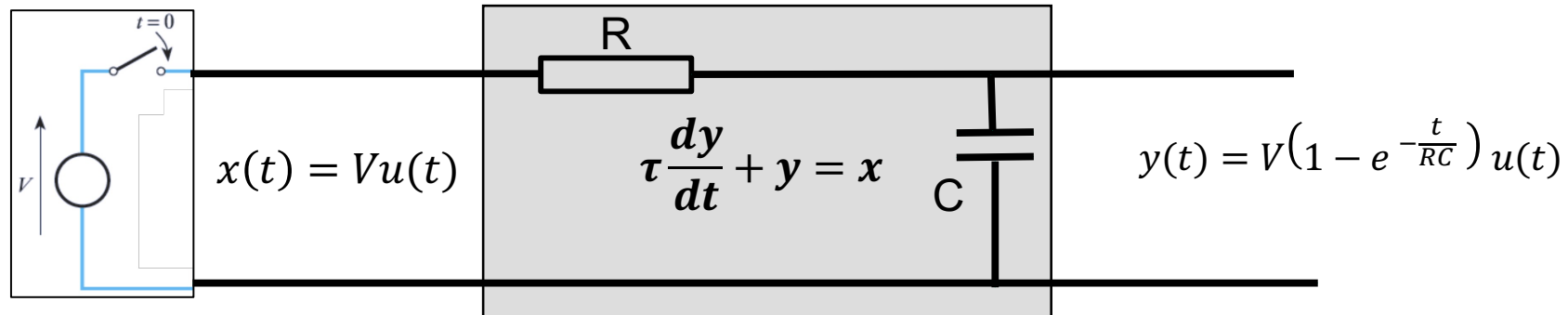

- ◆ Take LT of $x(t)$: $\mathcal{L}\{x(t)\} = X(s) = \mathcal{L}\{V \times u(t)\} = V \times \mathcal{L}\{u(t)\} = V \times \frac{1}{s}$
- ◆ Find **transfer function** $H(s)$ of the circuit by taking the Laplace Transform of the differential equation: $\tau s Y(s) + Y(s) = X(s)$

$$\Rightarrow H(s) = \frac{Y(s)}{X(s)} = \frac{1}{\tau s + 1}$$

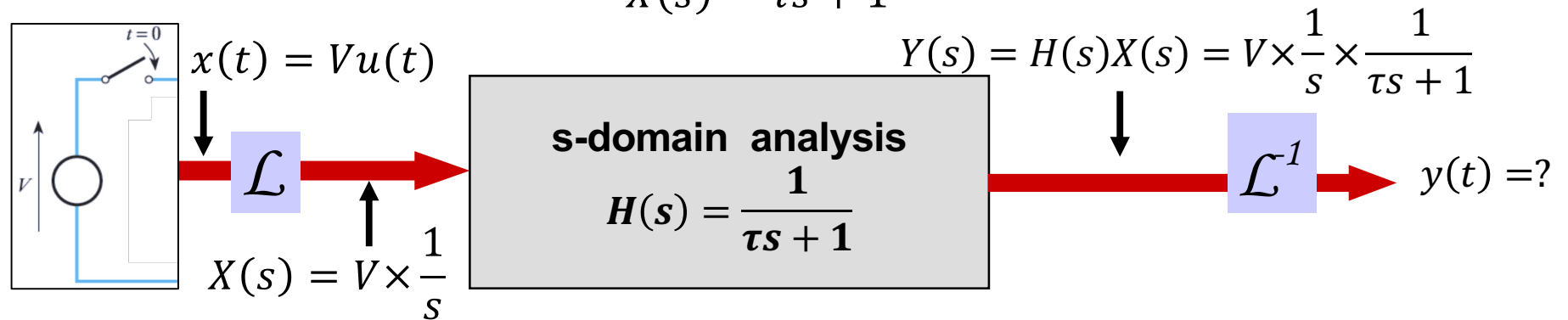

Forward & Inverse Laplace Transform

- ◆ Remember: the definition of the Laplace Transform \mathcal{L} is:

$$\mathcal{L}[x(t)] = X(s) = \int_0^{\infty} x(t)e^{-st} dt$$

- ◆ The definition of the Inverse Laplace Transform \mathcal{L}^{-1} is:

$$\mathcal{L}^{-1}[X(s)] = x(t) = \frac{1}{2\pi j} \int_{\sigma-j\omega}^{\sigma+j\omega} X(s)e^{st} ds, \quad \omega \rightarrow \infty$$

Finding Inverse Laplace Transform via partial fraction

- ◆ Finding inverse Laplace transform of $Y(s) = \frac{1}{s} \times \frac{1/\tau}{s + 1/\tau}$ (use partial fraction)

$$Y(s) = \frac{1}{s} \times \frac{1/\tau}{s + 1/\tau} = \frac{k_1}{s} + \frac{k_2}{s + 1/\tau}$$

- ◆ To find k_1 which corresponds to the term $(s+0)$ in denominator, cover up $(s+0)$ in $Y(s)$, and substitute $s = 0$ (i.e. $s+0=0$) in the remaining expression:

$$k_1 = \frac{1}{s} \times \frac{1/\tau}{s + 1/\tau} \Big|_{s=0} = 1$$

- ◆ Similarly for k_2 , cover the $(s+1/\tau)$ term, and substitute $s = -1/\tau$, we get:

$$k_2 = \frac{1}{s} \times \frac{1/\tau}{s + 1/\tau} \Big|_{s=-1/\tau} = -1$$

- ◆ Therefore

$$Y(s) = \frac{1}{s} - \frac{1}{s + 1/\tau}$$

L4.1

From Laplace Domain back to Time Domain

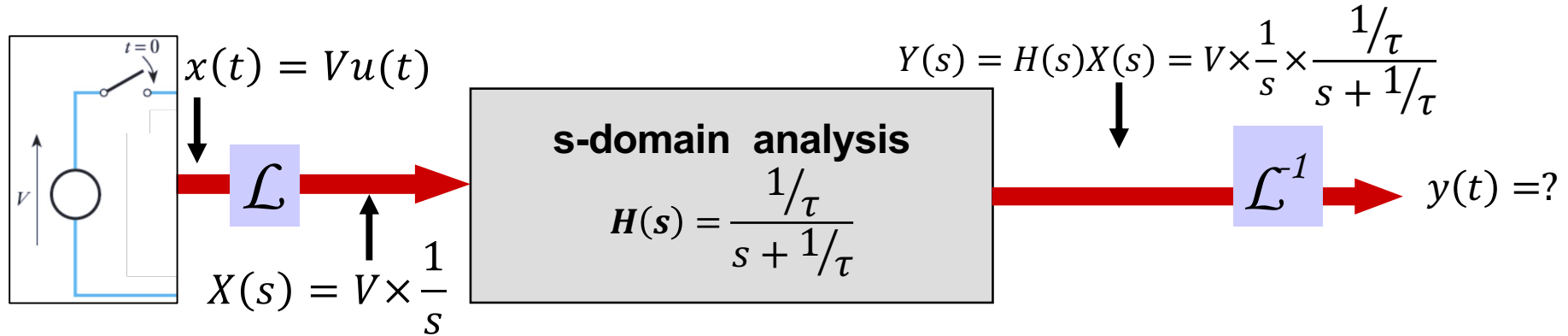

◆ So, we get: $Y(s) = V \left(\frac{1}{s} - \frac{1}{s + 1/\tau} \right)$

◆ Use Laplace Transform table, pair 5: $e^{\lambda t} u(t) \stackrel{\mathcal{L}}{\Leftrightarrow} \frac{1}{s - \lambda}$

$$\mathcal{L}^{-1}\{Y(s)\} = V \mathcal{L}^{-1} \left\{ \frac{1}{s} - \frac{1}{s + 1/\tau} \right\} = V \left(u(t) - e^{-\frac{t}{\tau}} u(t) \right) = V \times (1 - e^{-\frac{t}{\tau}}) \times u(t)$$

◆ Same as results from slide 14 using differential equation.

Another Examples of Inverse Laplace Transform

- ◆ Finding the inverse Laplace transform of $\frac{2s^2 - 5}{(s + 1)(s + 2)}$
- ◆ The partial fraction of this expression is less straight forward. If the power of numerator polynomial (M) is the same as that of denominator polynomial (N), we need to add the coefficient of the highest power in the numerator to the normal partial fraction form:

$$X(s) = 2 + \frac{k_1}{s + 1} + \frac{k_2}{s + 2}$$

- ◆ Solve for k_1 and k_2 via "covering":

$$k_1 = \frac{2s^2 + 5}{(s + 1)(s + 2)} \Big|_{s=-1} = \frac{2 + 5}{-1 + 2} = 7$$

- ◆ Therefore

$$X(s) = 2 + \frac{7}{s + 1} - \frac{13}{s + 2}$$

$$k_2 = \frac{2s^2 + 5}{(s + 1)(s + 2)} \Big|_{s=-2} = \frac{8 + 5}{-2 + 1} = -13$$

- ◆ Using pairs 1 & 5:

$$x(t) = 2\delta(t) + (7e^{-t} - 13e^{-2t})u(t)$$

L4.1

A video demonstrating an underdamped oscillatory system

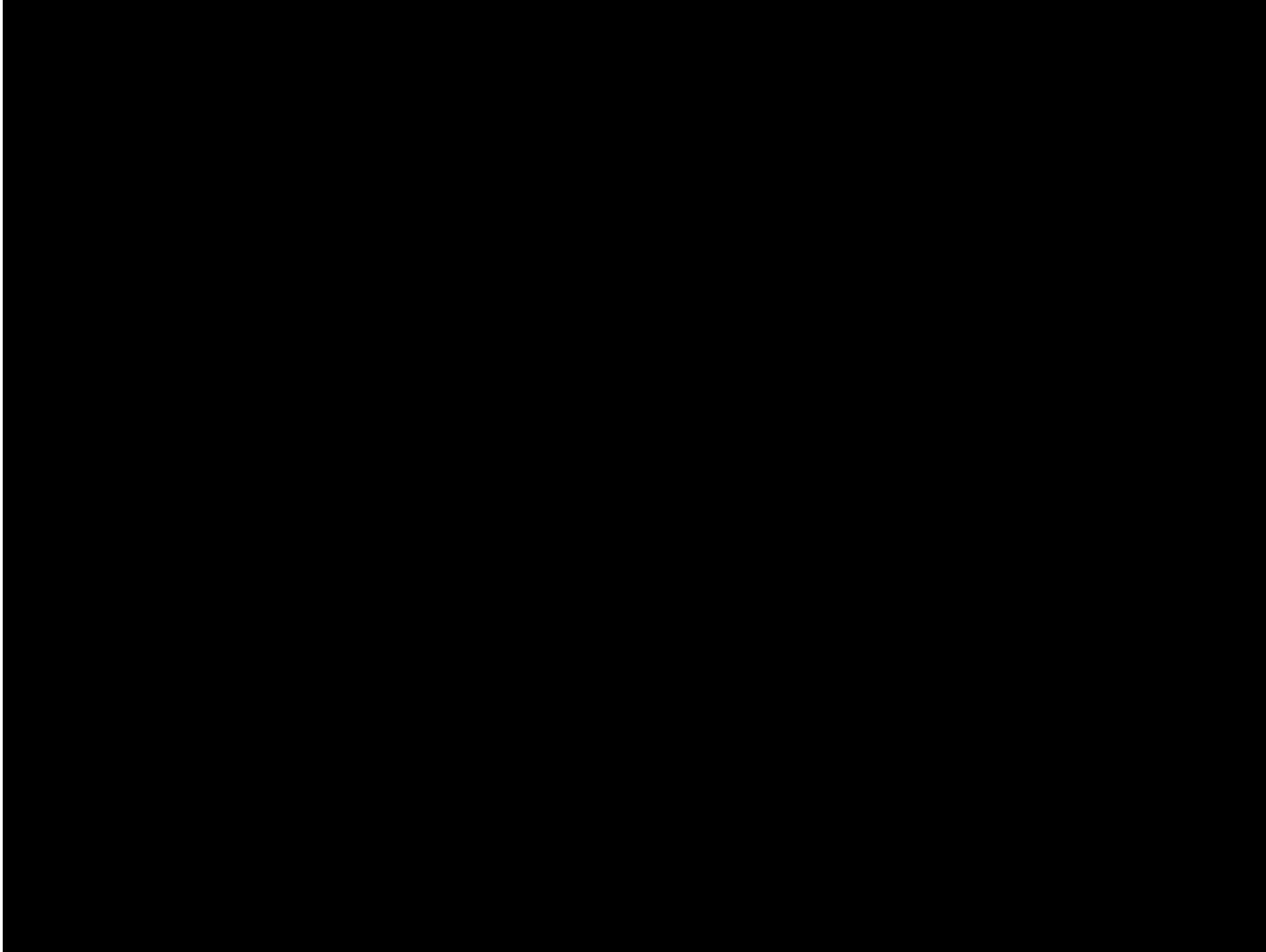

The Millennium Bridge

